

### 产品结构

介质：金属化聚丙烯薄膜  
 外壳：铝外壳封装  
 内部灌封：树脂填充 (UL94 V-0)

### 电气特性

工作温度：-40 至 +85 °C  
 容量范围：180 至 4800μF  
 额定电压：700 至 1200VDC  
 容量偏差：±5% , ±10%  
 损耗因素： $\leq 3 \times 10^{-3}$  @ 100 Hz, 20±5°C  
 预期寿命：100,000 小时 @ Un, 70 °C (热点温度)  
 极间耐压：1.5Un (DC) @ 10s, 20±5°C  
 极壳耐压：(1.5Un+1000)VAC, 最小 3000VAC (10s,50Hz)  
 绝缘电阻：(IR×Cn) 30000s (不超过 30GΩ),  
 100VDC (20±5°C), 1 分钟



### 应用

新能源逆变器 变频器 电机驱动 开关电源

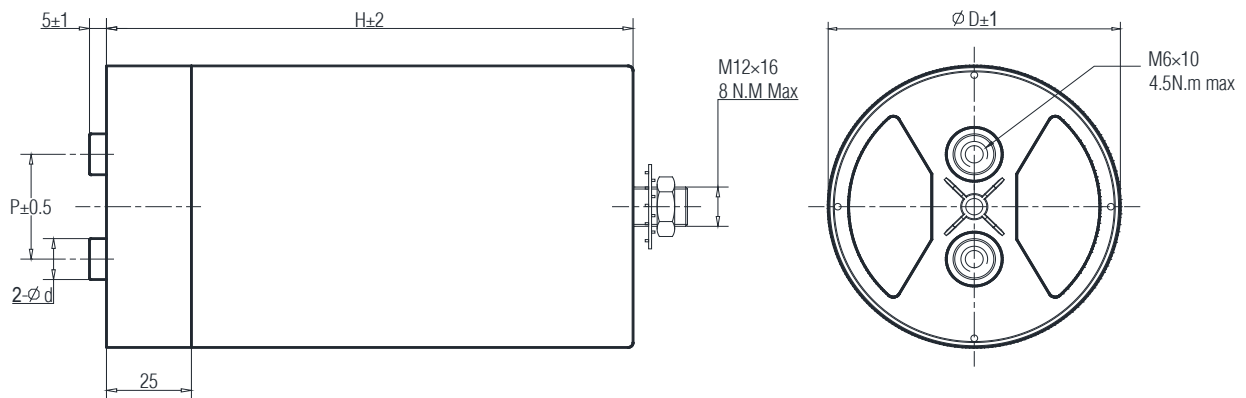

安装孔距与安装螺口外径尺寸

D= 76, 86mm	D= 96mm	D= 116mm	D= 136mm
d= 12.5mm	d= 12.5mm	d= 14mm	d= 14mm
P= 32mm	P= 45mm	P= 50mm	P= 50mm

## 特性参数

订货代码	容量 ( $\mu\text{F}$ )	D (mm)	H (mm)	Ipeak (A)	I <sub>Max</sub> @45°C @10KHz (A)	ESR@1.0KHz (m $\Omega$ )	Ls (nH)	Rth (k/W)	Wn (Ws)	重量 (Kg)
<b>Un 700VDC , Us 1050V , Ur 150V</b>										
SHP-700-500-FSB1	500	76	95	1652	43	1.8	≤50	4.6	123	0.58
SHP-700-680-FSB1	680	86	95	2247	48	1.6	≤50	3.9	167	0.73
SHP-700-700-FSB1	700	76	120	1705	44	1.9	≤60	4.1	172	0.70
SHP-700-800-FSB1	800	76	145	3365	60	1.1	≤45	3.7	196	0.88
SHP-700-845-FSB1	845	96	100	2793	54	1.6	≤50	3.3	207	0.95
SHP-700-900-FSB1	900	86	120	2192	49	1.8	≤60	3.5	221	0.89
SHP-700-1000-FSB1	1000	76	175	3305	62	1.2	≤50	3.3	245	1.04
SHP-700-1050-FSB1	1050	86	145	4416	66	1.1	≤45	3.2	257	1.11
SHP-700-1100-FSB1	1100	96	125	2679	55	1.7	≤60	3.0	270	1.15
SHP-700-1200-FSB1	1200	116	100	3966	60	1.5	≤50	2.6	294	1.38
SHP-700-1300-FSB3	1300	96	150	5468	72	1.1	≤45	2.7	319	1.43
SHP-700-1300-FSB1	1300	86	175	4296	68	1.1	≤50	2.9	319	1.31
SHP-700-1300-FSB2	1300	76	225	3166	64	1.3	≤60	2.9	319	1.28
SHP-700-1600-FSB1	1600	96	180	5288	74	1.1	≤50	2.5	392	1.68
SHP-700-1600-FSB2	1600	116	125	3896	60	1.6	≤60	2.3	392	1.67
SHP-700-1700-FSB2	1700	136	100	5618	60	1.4	≤50	2.1	417	1.89
SHP-700-1700-FSB1	1700	86	225	4140	71	1.2	≤60	2.5	417	1.62
SHP-700-1900-FSB1	1900	116	150	7992	82	1.0	≤45	2.1	466	2.06
SHP-700-2200-FSB1	2200	96	230	5357	78	1.1	≤60	2.2	539	2.07
SHP-700-2400-FSB1	2400	136	125	5844	60	1.5	≤60	1.9	588	2.25
SHP-700-2400-FSB2	2400	116	180	7932	85	1.0	≤50	2.0	588	2.41
SHP-700-2800-FSB1	2800	136	150	11777	93	1.0	≤45	1.7	686	2.82
SHP-700-3300-FSB1	3300	116	230	8036	90	1.1	≤60	1.7	809	2.96
SHP-700-3500-FSB1	3500	136	180	11567	96	1.0	≤50	1.6	858	3.30
SHP-700-4800-FSB1	4800	136	230	11689	100	1.0	≤60	1.4	1176	4.05
<b>Un 800VDC , Us 1200V , Ur 175V</b>										
SHP-800-370-FSB1	370	76	95	1427	42	1.8	≤50	4.6	118	0.58
SHP-800-490-FSB1	490	86	95	1889	48	1.7	≤50	3.9	157	0.73
SHP-800-500-FSB1	500	76	120	1420	43	2.0	≤60	4.1	160	0.71
SHP-800-580-FSB1	580	76	145	2846	59	1.2	≤45	3.7	186	0.89
SHP-800-600-FSB1	600	96	100	2313	53	1.6	≤50	3.3	192	0.95
SHP-800-680-FSB1	680	86	120	1932	49	1.8	≤60	3.5	218	0.88
SHP-800-700-FSB1	700	76	175	2699	60	1.2	≤50	3.3	224	1.03
SHP-800-750-FSB1	750	86	145	3680	65	1.1	≤45	3.2	240	1.12
SHP-800-820-FSB1	820	96	125	2330	54	1.7	≤60	3.0	262	1.15
SHP-800-900-FSB1	900	116	100	3470	60	1.5	≤50	2.6	288	1.37
SHP-800-900-FSB2	900	96	150	4416	71	1.1	≤45	2.7	288	1.45
SHP-800-950-FSB1	950	86	175	3663	67	1.2	≤50	2.9	304	1.31
SHP-800-1000-FSB1	1000	76	225	2841	63	1.3	≤60	2.9	320	1.28
SHP-800-1200-FSB1	1200	96	180	4627	74	1.1	≤50	2.5	384	1.67
SHP-800-1200-FSB2	1200	116	125	3409	63	1.6	≤60	2.3	384	1.66
SHP-800-1300-FSB1	1300	136	100	5012	60	1.5	≤50	2.1	416	1.87
SHP-800-1300-FSB2	1300	86	225	3693	70	1.2	≤60	2.5	416	1.62
SHP-800-1400-FSB1	1400	116	150	6870	82	1.0	≤45	2.1	448	2.06
SHP-800-1600-FSB1	1600	96	230	4546	77	1.2	≤60	2.2	512	2.07
SHP-800-1700-FSB1	1700	136	125	4830	60	1.5	≤60	1.9	544	2.28
SHP-800-1800-FSB1	1800	116	180	6940	85	1.1	≤50	2.0	576	2.39
SHP-800-2000-FSB1	2000	136	150	9814	92	1.0	≤45	1.7	640	2.84
SHP-800-2400-FSB1	2400	116	230	6818	89	1.1	≤60	1.7	768	2.97
SHP-800-2500-FSB1	2500	136	180	9639	95	1.0	≤50	1.6	800	3.32
SHP-800-3500-FSB1	3500	136	230	9943	100	1.1	≤60	1.4	1120	4.06

## 特性参数

订货代码	容量 ( $\mu$ F)	D (mm)	H (mm)	I <sub>peak</sub> (A)	I <sub>Max</sub> @45°C @10KHz (A)	ESR@1.0KHz (m $\Omega$ )	Ls (nH)	Rth (k/W)	Wn (Ws)	重量 (Kg)
<b>Un 1100VDC , Us 1650V , Ur 225V</b>										
SHP-1100-220-FSB1	220	76	95	1042	40	2.0	≤50	4.6	133	0.59
SHP-1100-300-FSB2	300	86	95	1421	46	1.8	≤50	3.9	182	0.73
SHP-1100-300-FSB1	300	76	120	1047	40	2.3	≤60	4.1	182	0.72
SHP-1100-345-FSB1	345	76	145	2080	57	1.2	≤45	3.7	209	0.89
SHP-1100-360-FSB1	360	96	100	1705	51	1.7	≤50	3.3	218	0.97
SHP-1100-400-FSB1	400	86	120	1396	46	2.0	≤60	3.5	242	0.90
SHP-1100-450-FSB1	450	76	175	2132	59	1.3	≤50	3.3	272	1.04
SHP-1100-460-FSB1	460	86	145	2773	63	1.2	≤45	3.2	278	1.12
SHP-1100-490-FSB1	490	96	125	1710	52	1.9	≤60	3.0	296	1.18
SHP-1100-550-FSB1	550	96	150	3316	70	1.1	≤45	2.7	333	1.45
SHP-1100-550-FSB2	550	116	100	2605	60	1.6	≤50	2.6	333	1.40
SHP-1100-600-FSB0	600	86	175	2842	65	1.2	≤50	2.9	363	1.31
SHP-1100-600-FSB2	600	76	225	2094	60	1.4	≤60	2.9	363	1.30
SHP-1100-720-FSB1	720	96	180	3411	72	1.2	≤50	2.5	436	1.71
SHP-1100-750-FSB1	750	116	125	2618	60	1.7	≤60	2.3	454	1.68
SHP-1100-800-FSB1	800	136	100	3790	60	1.5	≤50	2.1	484	1.91
SHP-1100-800-FSB0	800	86	225	2792	68	1.3	≤60	2.5	484	1.63
SHP-1100-850-FSB1	850	116	150	5124	81	1.1	≤45	2.1	514	2.11
SHP-1100-980-FSB1	980	96	230	3421	75	1.2	≤60	2.2	593	2.11
SHP-1100-1050-FSB1	1050	136	125	3665	60	1.6	≤60	1.9	635	2.31
SHP-1100-1050-FSB2	1050	116	180	4974	83	1.1	≤50	2.0	635	2.47
SHP-1100-1200-FSB1	1200	136	150	7234	91	1.0	≤45	1.7	726	2.91
SHP-1100-1400-FSB1	1400	116	230	4886	87	1.2	≤60	1.7	847	3.07
SHP-1100-1500-FSB1	1500	136	180	7105	94	1.1	≤50	1.6	908	3.41
SHP-1100-2100-FSB1	2100	136	230	7330	98	1.1	≤60	1.4	1271	4.17
<b>Un 1200VDC , Us 1800V , Ur 250V</b>										
SHP-1200-180-FSB1	180	76	95	952	40	2.1	≤50	4.6	130	0.58
SHP-1200-230-FSB1	230	86	95	1216	45	1.9	≤50	3.9	166	0.74
SHP-1200-250-FSB1	250	76	120	974	40	2.3	≤60	4.1	180	0.71
SHP-1200-280-FSB1	280	76	145	1884	56	1.3	≤45	3.7	202	0.89
SHP-1200-300-FSB1	300	96	100	1586	51	1.8	≤50	3.3	216	0.97
SHP-1200-330-FSB1	330	86	120	1286	45	2.1	≤60	3.5	238	0.89
SHP-1200-360-FSB1	360	76	175	1904	58	1.3	≤50	3.3	259	1.04
SHP-1200-380-FSB1	380	86	145	2557	63	1.2	≤45	3.2	274	1.11
SHP-1200-400-FSB1	400	96	125	1558	51	1.9	≤60	3.0	288	1.16
SHP-1200-450-FSB1	450	116	100	2379	60	1.6	≤50	2.6	324	1.39
SHP-1200-480-FSB1	480	86	175	2538	65	1.2	≤50	2.9	346	1.31
SHP-1200-500-FSB1	500	76	225	1948	60	1.5	≤60	2.9	360	1.29
SHP-1200-580-FSB1	580	96	180	3067	71	1.2	≤50	2.5	418	1.69
SHP-1200-600-FSB1	600	116	125	2338	60	1.7	≤60	2.3	432	1.68
SHP-1200-650-FSB1	650	136	100	3437	60	1.5	≤50	2.1	468	1.90
SHP-1200-680-FSB0	680	86	225	2649	67	1.3	≤60	2.5	490	1.61
SHP-1200-700-FSB2	700	116	150	4711	80	1.1	≤45	2.1	504	2.09
SHP-1200-780-FSB1	780	96	230	3039	74	1.3	≤60	2.2	562	2.10
SHP-1200-880-FSB1	880	136	125	3429	60	1.6	≤60	1.9	634	2.29
SHP-1200-880-FSB2	880	116	180	4653	83	1.1	≤50	2.0	634	2.44
SHP-1200-1000-FSB1	1000	136	150	6730	91	1.0	≤45	1.7	720	2.89
SHP-1200-1200-FSB1	1200	116	230	4675	86	1.2	≤60	1.7	864	3.02
SHP-1200-1300-FSB1	1300	136	180	6874	94	1.1	≤50	1.6	936	3.34
SHP-1200-1700-FSB1	1700	136	230	6624	98	1.1	≤60	1.4	1224	4.17