

大电流谐振 隔值 AC 应用

外 壳：	塑料外壳封装
工作温度：	- 40 °C 至 + 105 °C (Ths≤105°C)
容量范围：	0.90 至 10μF (± 5% , ± 10%)
额定电压：	400 至 1000 VAC

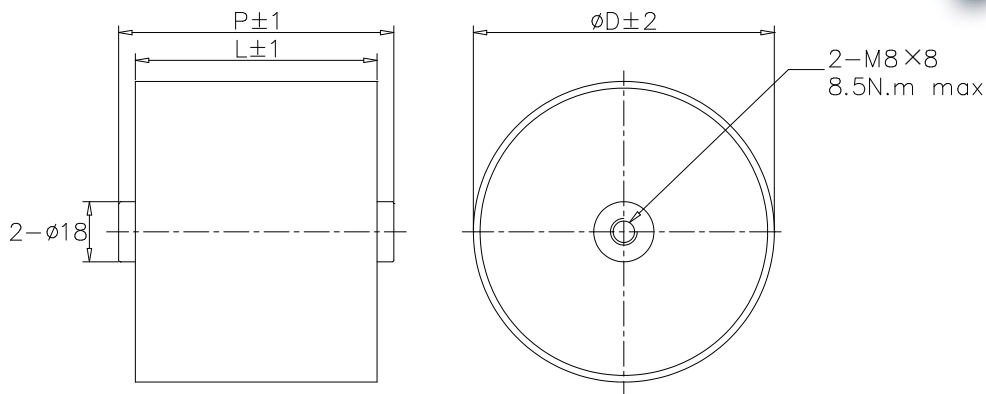

特性参数

订货代码	容量 (μF)	Urms (Vac)	D (mm)	L (mm)	P (mm)	Du/dt (v/μs)	I <sub>Max</sub> @60°C 10KHZ(A)	ESR@100KHz (mΩ)	Rth (k/w)
<b>Urms 400VAC, Un 570VAC, Undc 1200VDC</b>									
SCV-400-3.0-40F8	3.0	400	60	40	50	552	58	2.0	9.1
SCV-400-4.5-40F8	4.5	400	70	40	50	551	69	1.7	7.3
SCV-400-6.0-40F8	6.0	400	80	40	50	550	80	1.6	6.0
SCV-400-7.0-40F8	7.0	400	85	40	50	549	85	1.5	5.5
SCV-400-10-50F8	10	400	85	50	61	373	85	1.6	5.2
<b>Urms 500VAC, Un 710VAC, Undc 1400VDC</b>									
SCV-500-2.0-40F8	2.0	500	60	40	50	689	55	2.2	9.1
SCV-500-3.0-40F8	3.0	500	70	40	50	687	67	1.9	7.3
SCV-500-4.0-40F8	4.0	500	80	40	50	685	77	1.7	6.0
SCV-500-4.7-40F8	4.7	500	85	40	50	685	82	1.6	5.5
SCV-500-7.5-50F8	7.5	500	85	50	61	431	83	1.7	5.2
<b>Urms 700VAC, Un 990VAC, Undc 2000VDC</b>									
SCV-700-0.90-40F8	0.90	700	60	40	50	1115	48	2.8	9.1
SCV-700-1.3-40F8	1.3	700	70	40	50	1110	60	2.3	7.3
SCV-700-1.8-40F8	1.8	700	80	40	50	1107	71	2.0	6.0
SCV-700-2.0-40F8	2.0	700	85	40	50	1106	75	1.9	5.5
SCV-700-3.3-50F8	3.3	700	85	50	61	696	77	2.0	5.2
<b>Urms 1000VAC, Un 1410VAC, Undc 3200VDC</b>									
SCV-1000-1.0-64F8	1.0	1000	60	64	74	1476	49	3.2	7.7
SCV-1000-1.3-64F8	1.3	1000	70	64	74	1473	59	2.8	6.2
SCV-1000-1.8-64F8	1.90	1000	80	64	74	1470	70	2.3	5.2
SCV-1000-2.2-64F8	2.2	1000	85	64	74	1468	77	2.1	4.8